

Noble Marine Streaker Class National Championships

June 29th 30th & July 1st 2018

Sailing Instructions

1 Governing Bodies

All Open Meeting Racing, officials and competitors shall be governed by the Rules defined in the Current Racing Rules of Sailing (RRS), except as shall be modified by these Sailing Instructions, the Rules of Carsington Sailing Club Ltd, the Rules of the appropriate Class and the requirements of Severn Trent Water Plc.

The organising authority is Carsington Sailing Club in conjunction with the Streaker Owners Class Association

- 1.1 Any procedures not covered by these Sailing Instructions will be carried out in accordance with the procedures defined in the current RRS 2017 - 2020.
- 1.2 Any Disputes under the Current Racing Rules of as modified by these Sailing Instructions shall be settled using the RYA Procedure for Rules Disputes.
- 1.3 Any conflict of information between these SI's and any other document – the SI's take precedent.

2 Entries.

3 General.

The safety of a boat, crew and her entire management including insurance, shall be the sole responsibility of the owner / person in charge, who must ensure that the boat and crew are adequate to face the conditions that may arise during the course of the race. Neither these Sailing Instructions, nor any inspection of the boat limits or reduces the absolute responsibility for any loss, damage, death or personal injury howsoever caused to or by the owner / person in charge or crew, as a result of taking part in a race or races. Moreover, every owner / person in charge warrants the suitability of their boat for the race or races. The boat shall have current 3rd party insurance of not less than £2 million.

Rule 4 of the Racing Rules of Sailing states: "The responsibility for a boat's decision to participate in a race or to continue racing is hers alone." Sailing is by its nature an unpredictable sport and therefore involves an element of risk. By taking part in the event, each competitor agrees and acknowledges that:

- a. They are aware of the inherent element of risk involved in the sport and accept responsibility for the exposure of themselves, their crew and their boat to such inherent risk whilst taking part in the event;
- b. They are responsible for the safety of themselves, their crew, their boat and their other property whether afloat or ashore;
- c. They accept responsibility for any injury, damage or loss to the extent caused by their own actions or omissions;
- d. Their boat is in good order, equipped to sail in the event and they are fit to participate;

- e. The provision of a race management team, patrol boats, umpires and other officials and volunteers by the organiser does not relieve them of their own responsibilities;
- f. The provision of patrol boat cover is limited to such assistance, particularly in extreme weather conditions, as can be practically provided in the circumstances.

A DECISION BY THE ORGANISERS TO GIVE COMPETITORS PERMISSION TO LAUNCH THEIR BOATS AND TO SAIL DOES NOT IMPLY THAT THE SAILING CONDITIONS ARE NECESSARILY SAFE FOR ALL COMPETITORS TO DO SO.

- 3.1 Race Entry/Declaration Sheet. A registration/entry form shall be completed prior to racing and the appropriate fee paid by the person in charge of each boat. The forms will be available from the Class Association or on the day near to the official Race Notice Board.
- 3.2 Signing off is not required for this event.
- 3.3 Valid Race.

The minimum number of starters of each Fleet to constitute a Valid Race shall be 2 (two).

A minimum wind strength of 4 knots is required to start a race.
- 3.4 Measurement / Certificates. A boat may be required to present her valid measurement certificate and / or racing certificate upon request by the Race Committee. Boats may be measured before or after any race at the sole discretion of the Race Committee.
- 3.5 Distinguishing Numbers. Boats shall display their Class boat number on their sail. In exceptional circumstances the Race Committee may accept written applications to use another distinguishing number on a sail as prescribed in RRS Appendix G. This complies with RRS 77.
- 3.6 Personal Buoyancy. All persons at all times when on the water shall wear correctly adjusted and properly secured adequate personal buoyancy. Wet and / or dry suits alone are not regarded as adequate personal buoyancy. If worn, Auto-inflation lifejackets must be on the outside of all clothing. This modifies RRS 40.
- 3.7 Radio Communication. A boat shall neither make nor receive radio communications whilst racing except in matters of safety on the water. This restriction also applies to mobile phones etc.

4 Notices to Competitors.

- 4.1 Notices to competitors will be posted on the official Race Notice Board located in the Clubhouse.

5 Signals Made Ashore.

- 5.1 These will be displayed on the Clubhouse flagpole that is situated at the South West corner of the front patio area of the Clubhouse.
- 5.2 IC Flag "AP" (Answering Pennant) displayed with 2 sound signals means "the current race is postponed" to be sailed later. The first warning signal for the start of the race will be made not less than 20 minutes after the IC Flag "AP" is removed, (1 sound signal).

6 Temporary Changes to Sailing Instructions.

- 6.1 Any temporary changes to these Sailing Instructions will be posted on the official Race Notice Board 45 minutes before the designated starting time of the race or races concerned. IC Flag "L" will be displayed on the Club flagpole.

7 Schedule of Races.

- 7.1 The Schedule and Starting Times of Races will be as published in the Notice of Race but may be subject to change on the day.

8 Start Flags.

- 8.1 Warning Signal flags to be used will be either class flag supplied by the class association or agreed with the Race Officer

9 Course Safety Instructions.

- 9.1 The Course area shall be all of the Sailing area of the reservoir except for the 'out of bounds' areas that are marked by either orange or white buoys.
- 9.2 The 'out of bounds' areas are at the Northern (Nature Reserve), Eastern (Diving Area, in creek behind mark 5) and Southern (adjacent to the tower) ends of the lake and it shall be prohibited to sail in these areas at all times.
- 9.3 Extra care should be taken in multi-user areas shared with Carsington Water Sports Centre. Craft from the Centre may be crewed by persons with no knowledge of collision and avoidance rules. Boats shall keep clear of these craft at all times. These craft shall be designated "an obstruction" as defined in RRS definitions.
- 9.4 When I C Flag "A" is displayed on the orange buoys marking the diving area, this indicates that divers are active. Please keep clear.
- 9.5 No spinnaker shall be flown in the "Bay Area" in front of the club house and closer to shore than a line from the race hut on the island to the yellow mark on the dam wall. When I C Flag "E" is displayed on the Clubhouse flagpole, this Sailing Instruction is overruled.
- 9.6 Competitors shall wear adequate personal buoyancy at all times whilst afloat. Flag 'Y' will not be displayed; this changes Rule 40, Race Signals Y and the part 4 preamble

10 The Course.

- 10.1 As per Appendix A attached. The course to be used will be announced at the pre-race briefing and displayed on the committee boat.
- 10.2 No later than the warning signal, the race committee boat will display the course to be sailed

11 Marks

11.1 Outer end of start line - Dan Buoy displaying a Red Flag

11.2 Outer end of finishing line (where separate from start line) - Dan Buoy with a blue flag.

11.3 Rounding Marks – Large Orange inflatable buoys, which are not numbered.

12 The Start.

12.1 An Orange Flag displayed on a mast on the Committee Boat signifies that the Race Officer is in position at the Start Line and ready to commence racing with 5 minutes to go to the Warning Signal after the Orange Flag is raised.

12.2 The Starting Line will be between a mast displaying an Orange Flag on the Committee Boat and an Outer Distance Mark (start) (as defined in Sailing Instruction 11).

12.3 The Start Gate will be closed 4 minutes after the Start signal, including General Recalls if any, and will be signalled by removing the Orange Flag (No sound signal). No boat shall start once the gate is closed.

12.4 The warning flag will be shown at the competitor briefing.

13 The Finish.

- 13.1 The intention to finish a race will be by displaying a Blue Flag on the Committee Boat/Race Control Box with two sound signals as the leading boat is on the penultimate leg of the course. This modifies RRS "Race Signals".
- 13.2 The Finish Line will be between a mast displaying a Blue Flag on the Committee Boat and the Outer Finish Mark (as defined in Sailing Instruction 11).
- 13.3 All boats having finished shall keep clear of boats still racing.
- 13.4 There will be no race time limit. The target race time for the first boat will be 45 minutes.

Boats failing to finish within 15 minutes after the first boat sails the course and finishes will be scored according to their position on the course. This changes rules 35, A4 and A5 Failure to meet the target time will not be grounds for redress. This changes Rule 61.2(a)

14 Shortened Course

- 14.1 Courses may be shortened at any time at the sole discretion of the Race Committee. This changes Rule 32.1
- 14.2 If the race committee signals a shortened course from the race committee boat (displays flag S with two sounds) before boats have reached the mark prior to the finish line, boats must leave that final mark to port and proceed to the normal finish line. This changes rule 32.2.

15 Advisory Hearing/ Arbitration/Protests / Redress.

- 15.1 Protests and/or Requests for Redress shall be in writing and delivered to the Club Office within 30 minutes of the time of the last boat to finish in the Race. If races are sailed back to back, then the time limit commences from the time of the last boat to finish in the last Race.
- 15.2 The Protestor shall inform the Race Officer of his/her intention to protest either on the water or immediately on both coming ashore.
- 15.3 Notices will be posted on the official Race Notice Board specifying the time and place of the hearing/s.
- 15.4 As provided in RRS 67, the Protest Committee may, without a hearing, penalize a boat that has broken RRS 42.

16 Scoring.

The Scoring Penalty, Rule 44.3, will not apply.

Three (3) races are required to be completed to constitute a series.

When fewer than 5 races have been completed, a boat's series score will be the total of her race scores.

When 5, 6 or 7 races have been completed, a boat's series score will be the total of her race scores excluding her worst score.

17 Insurance

- 17.1 Each participating boat shall be insured with valid third-party liability insurance with a minimum cover of £2,000,000 per incident.

18 Rights to use name and likeness

By participating in this event, competitors automatically grant to the organising authority and event sponsors the right, in perpetuity, to make, use, and show, at their discretion, any photography, audio and video recordings, and other reproductions of them made at the venue or on the water from the time of their arrival at the venue until their final destination, without compensation.

APPENDIX A Courses

The course for this regatta will be “triangle sausage triangle” using either course A shown in figure 1 or course B shown in figure 2, depending on conditions:

Subject to the wind and at the discretion of the Race Officer, a trapezoid course may be used, described as course C in figure 3

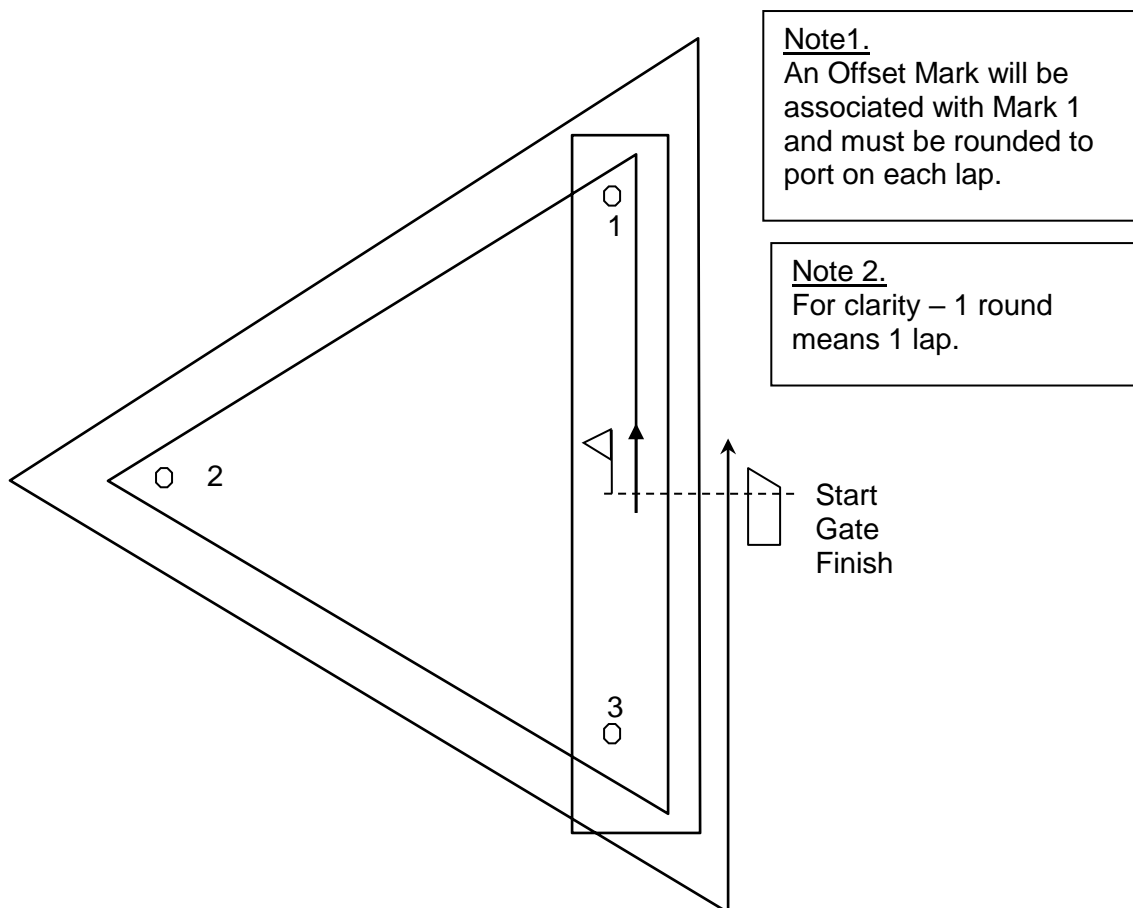

Figure 1: Course A

Course A: Marks 1, 2, 3, Gate, 1, 3, Gate, 1, 2, 3. The gate must be passed through on all upwind legs.

Round 1, 3 etc: 1, 2, 3 Gate

Round 2,4 etc: 1, 3, Gate

Repeat number of rounds displayed, then Finish

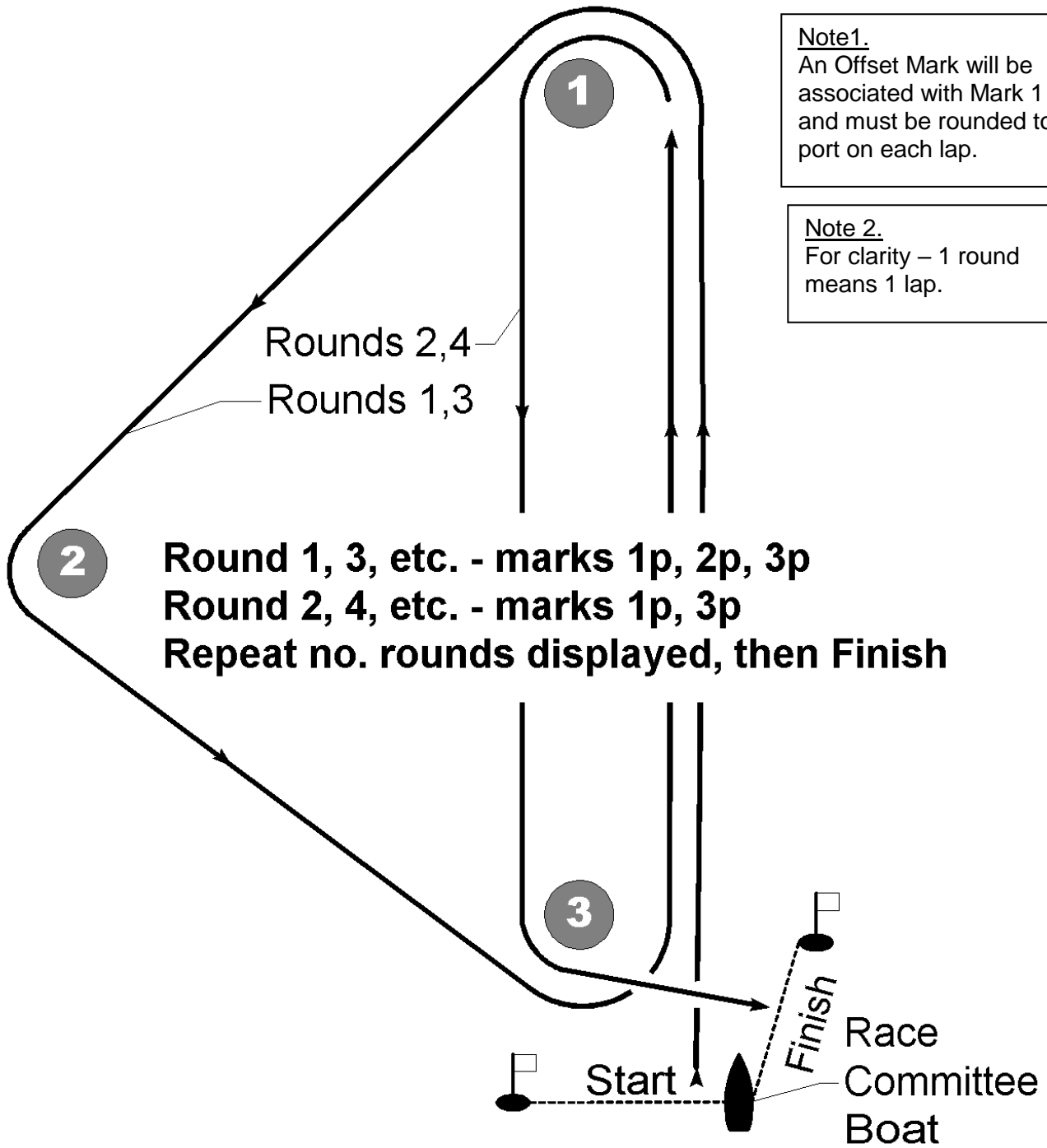

Figure 2 Course B:

Course C (Trapezoid) The number of laps (described as beats) to be sailed and the order of the marks will be displayed in advance in the Club House notice board.

1. All marks to Port.
2. Marks 1, 2, and 3 and 4 will be orange inflatable buoys.
3. Start mark will be a danbuoy with Orange flag
4. Finish mark (if different from the start mark) will be a danbuoy with Blue flag